



registriert im Firmenbuch Eisenstadt, FN 110178 b,
Umsatzsteuer-Identifikationsnummer ATU 21012302

Austria, A 7143 Apetlon, Söllnergasse 3
Telefon 02175-3264
office@conpexim.at
www.conpexim.at

FORSTMASCHINEN 1.2024

I) RUNGENWAGEN

CRANIT wahlweise mit 2WD oder 4WD

KRÄNE	F6S	G 7000	F 85
Reichweite	6 m	7 m	8,5 m
Hubkraft bei 4 m	1.250 kg	1.270 kg	1.950 kg
Hubkraft voller Reichweite	800 kg	730 kg	930 kg
Rotor/Greifer	3 t, GF 130, 130 cm	4,5 t, GRF 130, 130 cm	6 t, GRF 150, 150 cm
Ölpumpe	42 L/min. + MP	60 L/min. + MP	110 L/min. + MP
Hubmoment	50,6 kN/m	51,3 kN/m	79 kN/m
Schwenkmoment	14 kN/m	28 kN/m	30,8 kN/m
Serie	Ölkühler, Bent-Pump, Klappstützen hydraulisch, 400° Schwenkbereich, 2 Hebelsteuerung v. Hydrocontrol, Drossel zur Ölmenge regulierung, Zylinderschutz		
Ausschub hydraulisch	1*133 cm	2*118 cm	2*141 cm

WAGEN				
Typ	Maße	Nutzlast	Ladefläche/Volumen	Reifen
RF 10 EX	3,64 - 4,44*2,05 m	10 t	2,6 m ² / 11,54 m ³	400/60*15,5 16 ply
RF 12	4,44*2,05 m	12 t	2,6 m ² / 11,54 m ³	400/60*15,5 16 ply
RF 12 EX	3,64 - 4,44*2,05 m	12 t	2,6 m ² / 11,54 m ³	400/60*15,5 16 ply
RF 16	4,5*2,28 m	14 t	2,9 m ² / 13,05 m ³	500/45R22,5 16 ply
RF 16 EX	3,7-4,5*2,28 m	14 t	2,9 m ² / 13,05 m ³	500/45R22,5 16 ply

Serie:	Beleuchtung, Pendel-Tandemachse, Deichsellenkung hydraulisch mit 2 Zylindern, mit TR-Profil, 4 Rungenpaare, 2-Achsen hydraulisch gebremst
Antrieb	15,5" Felgen Sampo Motoren BBC2 mit 1.018 ccm ³ , sonst BB5 mit 1.600 ccm ³
Anmerkung	EX = hydr. Rahmenausschub 80 cm

PREISBEISPIELE incl. Mwst			
Kräne	F6S	G 7000	F 85
Wagen: RF 10 EX	€ 35.076	€ 39.864	€ 46.452
RF 12 L	€ 34.270	€ 39.064	€ 45.653
RF12 EX	€ 35.236	€ 40.030	€ 46.619
RF 12 EX 4 WD	€ 61.674	€ 66.468	€ 73.057
RF 16	---	€ 45.222	€ 51.811
RF 16 4WD	---	€ 66.924	€ 73.513

Optionen:	€ 835	Hochsitz (wahlweise Stehpodest)
	€ 346	Stundenzähler (digital)
GG 1000 X	€ 3.377	Seilwinde mit Funk, am Kranarm montiert, 30 m Seil - 8 mm stark
	€ 2.388	Kransteuerung elektr. On/off
PVG 32	€ 16.555	Danfoss Proportional-Steuerung mit Display, F6S/G7000
PVG 32	€ 15.373	Danfoss Proportional-Steuerung mit Display, F85



Hochsitz mit Funkseilwinde

CRANIT KRÄNE, technische Daten

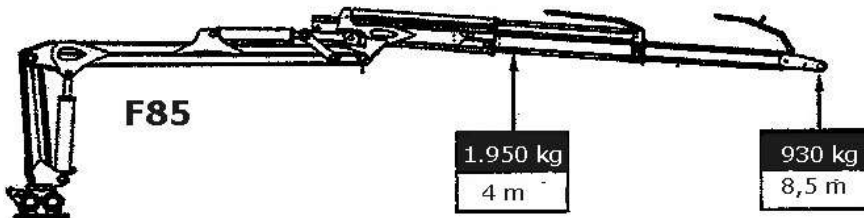
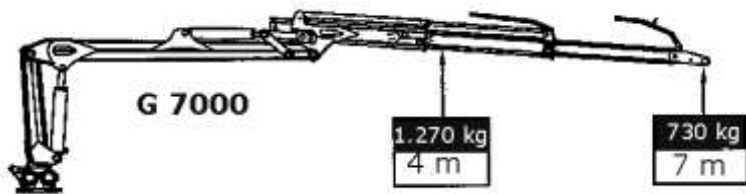
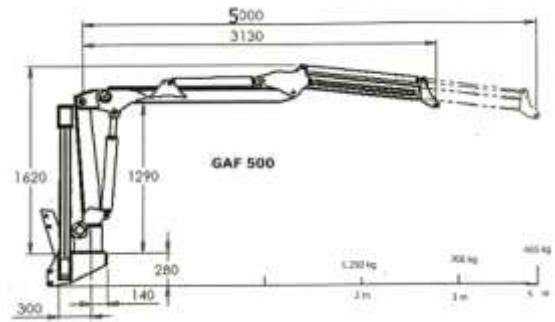
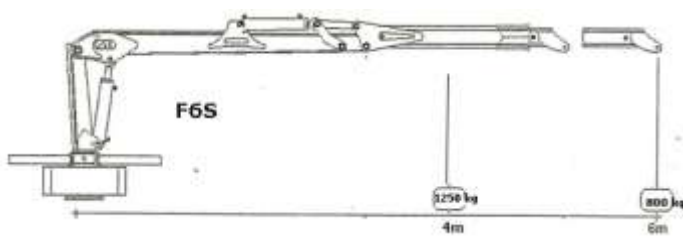

mit Hochsitz



ZIRN HOLZ 450 cm



BAUHOLZ



G7000



RF12L + F85



Antrieb



2-Hebel hydr. (Standard)



2 Hebel elektr. On/off



Ölkühler



Seilwinde am Kranarm mit Funk



DL Bremse



G7000 am Traktor



SAMPO
Radnabenmotor

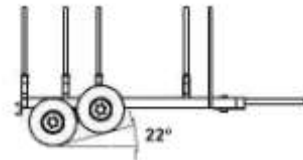

Deichsellenkung

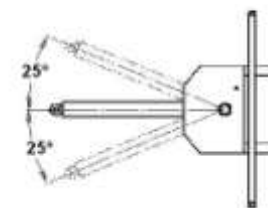

II) FORST-SEILWINDEN hydraulisch, 280 bar, mit Funkbedienung

CRANIT - Getriebe-Seilwinden hydraulisch für Festanbau, (an Traktore, Bagger, Ruckezüge) mit 80 m Seil

Typ	GFH 4000	GFH 7000	GFH 10000
Abmessungen B/H/T	610*400*530 mm	785*504*640 mm	785*504*640 mm
Gewicht	160 kg	210 kg	360 kg
Ölbedarf, Liter pro min.	50 l	60 l	70 l
Zugkraft	4 t	7 t	10 t
Seilstärke	Ø 10 mm	Ø 12 mm	Ø 13 mm
Preis	€ 6.636	€ 7.630	€ 10.350
Option:			
ohne Funkbedienung	-€ 696	-€ 696	-€ 696
ohne Seil	- € 180	- € 204	- € 228



III) FORSTMULCHER mit Ketten

- 1) **Kettenmulcher mit hydr. Motor, für Bagger**, mit 20 mm Ketten bis 10 cm Unterholz, Ölbedarf 200-270 bar

Typ	Arbeitsbreite	Gewicht	Ketten	Schnitthöhe	Ölbedarf	Preise
CMI 080	80 cm	180 kg	2/13 mm	30/70 mm	30-50 l	€ 2.915
CMI 100	100 cm	250 kg	2/13 mm	30/70 mm	40-60 l	€ 3.817
CMI 120	120 cm	320 kg	4/16 mm	30/70 mm	50-80 l	€ 4.224
CMI 150	150 cm	550 kg	4/20 mm	40/80 mm	60-120 l	€ 5.544



- 2) **Kettenmulcher, fix Typ CPR, fix**, 4 Ketten 20 mm stark, bis 8 cm Unterholz

Typ	AB	PS-Bedarf	kg	Preise
CPR 1.5	1,5 m	60-80	470	€ 2.676
CPR 1.6	1,6 m	70-90	510	€ 2.760
CPR 1.8	1,8 m	80-110	650	€ 3.852



- 3) **Kettenmulcher, mit Seitenverschub Typ CPR-H**, 25 cm hydr. Seitenverschub, 4 Ketten, 20 mm stark, bis 8 cm Unterholz

Typ	AB	PS-Bedarf	kg	Preise
CPL 1.5 H	1,5 m	60-80	520	€ 4.140
CPL 1.8 H	1,8 m	80-110	815	€ 5.340

IV) FORSTMULCHER, mittelschwer, Hämmer

	1,80 m	2,00 m	2,20 m	2,50 m	2,80 m
PERFECT	€ 8.890	€ 9.320	€ 9.510	€ 10.320	€ 11.320
PERFECT REVERS	€ 10.490	--	€ 10.570	€ 12.200	€ 13.000
Leistung	Äste/Stämme 12 bis 15 cm				
Serie	Stützrolle, Ø 220 mm, Getriebe mit Freilauf, hydr. Seitenverschub, Gelenkwelle				
Option:	mit Rückwand hydraulisch				
PERFECT REVERS	Anhängung: HECK + FRONT				



V) FORSTMULCHER, schwer

Forstmulcher LOMANI, mittelschwer, für Stämme/Äste bis 18 cm Durchmesser, Rotor 435 mm Durchmesser, 540 U/min., Gleitkufen, Hämmer, Rückwand hydraulisch				
Arbeitsbreite	150 cm	180 cm	200 cm	225 cm
Gewicht	1.040 kg	1.182 kg	1.284 kg	1.385 kg
Kraftbedarf	70 – 130 PS	75 – 130 PS	90 – 130 PS	90 – 130 PS
Preise	€ 15.870	€ 16.410	€ 17.100	€ 18.000
Option				
Gelenkwelle	€ 520			
Umkehrgetriebe	€ 660			
Schutzbalken	€ 910			
Schutzbalken hydr.	€ 1.620			
Stützwalze	€ 1.520			





VI) ERDBOHRER

Typ	Erdbohrer , hydr. Seitenvershub für Zapfwellenantrieb, Gelenkwelle mit Überlastsicherung
-----	---

HPO	Standard, mech. verschiebbar	€ 2.343
HPOH	Hydr. Seitenvershub	€ 2.649
HPOIH	mit Vor- und Rücklauf-Getriebe + hydr. SW	€ 3.929
Bohrer 1 m	Ø 150 mm (Ersatzmesser 1 Stk. € 50)	€ 300
Bohrer 1 m	Ø 300 mm (Ersatzmesser 1 Stk. € 60)	€ 440
Bohrer 1 m	Ø 450 mm (Ersatzmesser 1 Stk. € 70)	€ 680
Bohrer 1 m	Ø 600 mm (Ersatzmesser 1 Stk. € 80)	€ 780



Preise:	incl. 20 % MWST
Gültigkeit:	vorbehaltlich Rückbestätigung
Fracht:	Preise gelten ab Werk, Fracht wird nach Aufwand verrechnet
	Gerne helfen wir Ihnen bei einer Raiffeisen Leasing Finanzierung
	7143 Apetlon, Söllnergasse 3 Telefon: 02175-3264 Internet: www.conpexim.at e.mail: office@conpexim.at
Apetlon	02.01.2024
Ansprechpartner:	Herr Herbert Göttl